

Our Most Important Connection is with You.™

**SPnT Low PIM up to 18 GHz**



To meet growing market demands created by the deployment of 4G/LTE networks, Radiall has introduced a new range of Low PIM switches. RAMSES SPnT Low PIM switches are perfectly suited for RF test systems and test benches requiring excellent passive intermodulation performance up to 18 GHz, with a guarantee PIM performance of -160 dBc @ +43 dBm over a life span of 2 million switching cycles.

These products are specific to instrumentation and telecommunication applications.

Example of P/N:  
R573403600LP is a SP6T SMA up to 18 GHz, Normally Open, 28 Vdc, without option and solder pins.

**PART NUMBER SELECTION**

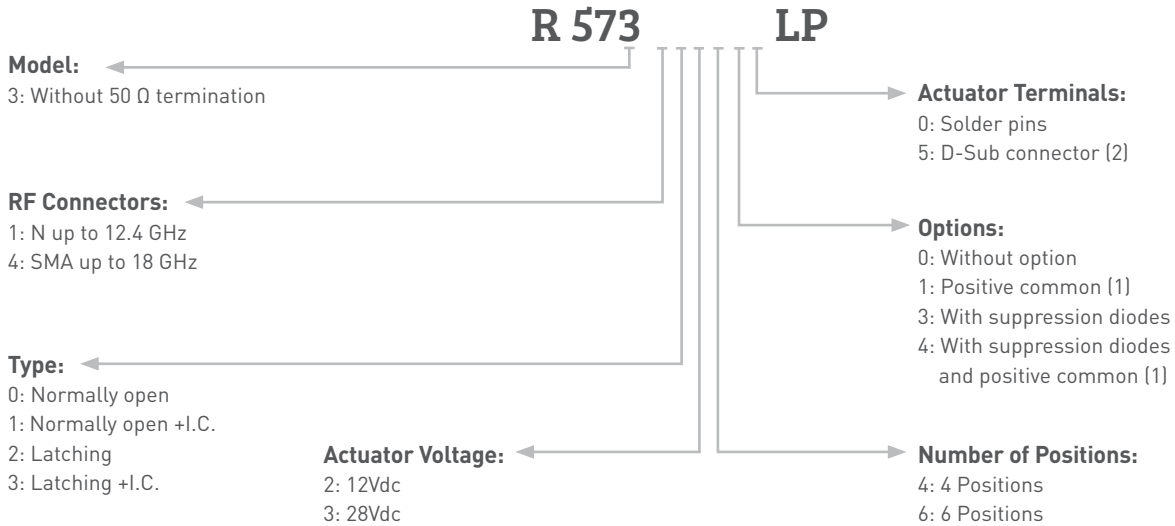

I.C.: Indicator contact  
(1) Standard products are equipped with negative common  
(2) Only for N models

**SPnT Low PIM up to 18 GHz**

**GENERAL SPECIFICATIONS**

Operating mode		Normally open		Latching	
Nominal operating voltage (across operating temperature)	Vdc	12 (10.2 to 13)	28 (24 to 30)	12 (10.2 to 13)	28 (24 to 30)
Coil resistance at 23°C (+/-10%)	Ω	47.5	275	38	225
Nominal operating current at 23°C	mA	250	102	320 Reset SP4T: 1280 mA* Reset SP6T: 1920 mA*	125 Reset SP4T: 500 mA* Reset SP6T: 750 mA*
Average power		See Power Rating Chart on page <b>1-13</b>			
TTL input	High Level	2.2 to 5.5 V ( TTL Option ) / 3.5 to 5.5 V ( BCD Option )			
	Low Level	0 to 0.8 V ( TTL Option ) / 0 to 1.5 V ( BCD Option )			
Indicator rating		1 Watt / 30 V / 100 mA			
Switching time (Max)	ms	15			
Life (Min)		2 million cycles			
Connectors		SMA - N			
Actuator terminals		Solder pins or male 25 pin D-Sub connector			
Operating temperature range		-40°C to +85°C			
Storage temperature range		-55°C to +85°C			
Vibration (MIL STD 202, method 204D, cond.D)		10-2000 Hz , 20g operating for SP3 to 6T			
Shock (MIL STD 202, method 213B, cond.C)		100g / 6 ms, ½ sine operating for SP3 to 6T			

\*Reset: supply voltage time 1 sec. max./duty cycle 10%

**RF PERFORMANCES**

Connectors	Number of positions	Frequency range GHz	V.S.W.R. (max)	Insertion loss (max) dB	Isolation (min) dB	Impedance Ω	Third order intermodulation
SMA	4 and 6	DC - 18	DC - 3	1.20	0.20	80	-160 dBc @ +43 dBm (2 carriers 20W)
			3 - 8	1.30	0.30	70	
			8 - 12.4	1.40	0.40	60	
			12.4 - 18	1.50	0.50	60	
N	DC - 12.4	DC - 3	1.20	0.20	80		
		3 - 8	1.35	0.35	70		
		8 - 12.4	1.50	0.50	60		

**OUTSTANDING PIM PERFORMANCE**

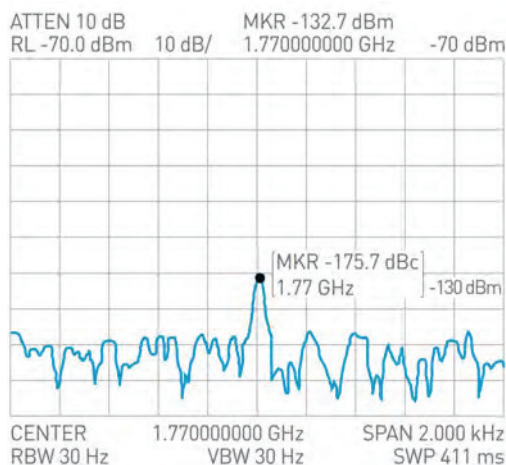

**Passive Intermodulation**

Tone 1	1810 MHz, approximately 43 dBm
Tone 2	1850 MHz, approximately 43 dBm
3rd order PIM	160 dBc at 1770 MHz

Depending on application, carrier powers and frequencies, PIM measurements can vary. PIM testing is not measured during product acceptance test.

Our Most Important Connection is with You.™

**SPnt Low PIM up to 18 GHz**

**TYPICAL RF PERFORMANCES**

Example: SP6T N up to 12.4 GHz

**Insertion Loss and Isolation**

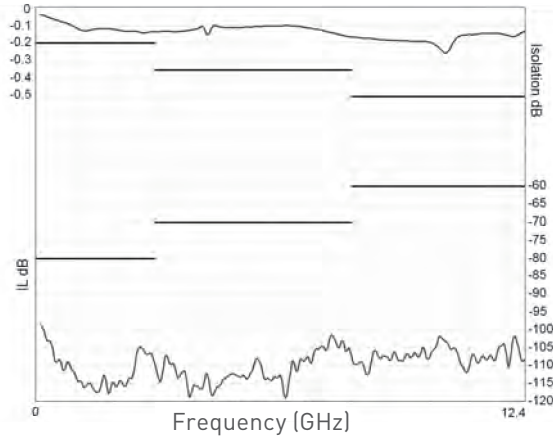

**V.S.W.R.**

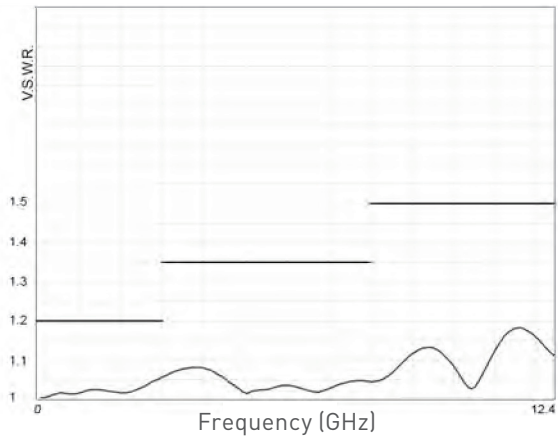

Example: SP6T SMA up to 18 GHz

**Insertion Loss and Isolation**

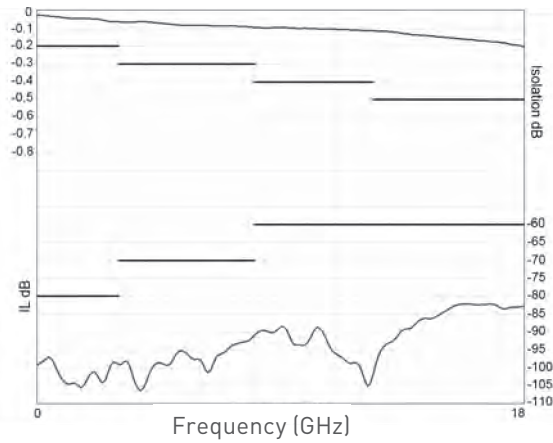

**V.S.W.R.**

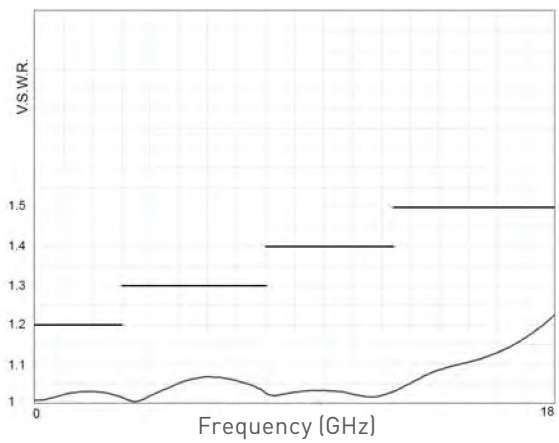

**SPnt Low PIM up to 18 GHz**

**TYPICAL OUTLINE DRAWING**

Example: SPnT N up to 12.4 GHz

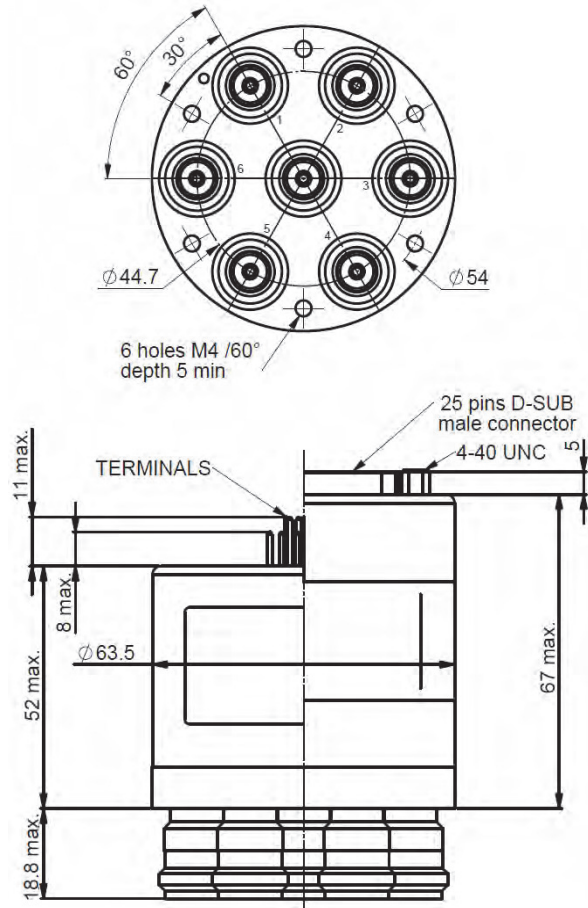

Example: SPnT SMA up to 18 GHz

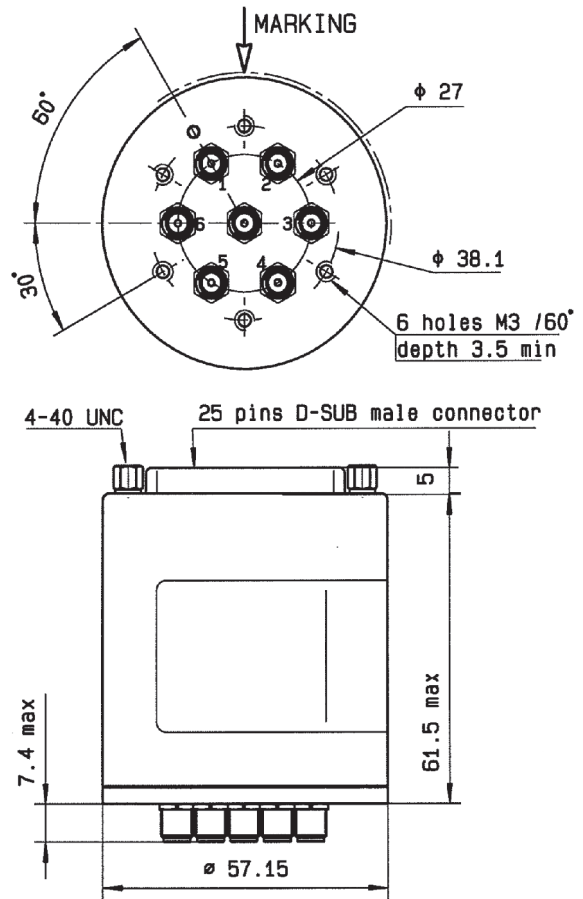

**RF CONNECTORS ALLOCATION**

SP4T

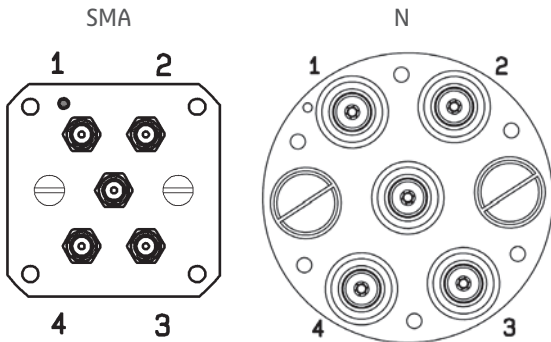

SP6T

